



SM Surgical Manual

SM Implant System Concept, Package System, SM / IFI Surgical kit, SM / SM Int. Master Surgical kit
Prosthetic Surgical kit, Implant Closing & Healing, SM-ExtraWide Implant



The background of the right side of the page features a grayscale image of several dental implants. The implants are shown from various angles, highlighting their threaded surfaces and conical shapes. The lighting creates soft shadows, giving a three-dimensional appearance to the objects.

Contents

1. SM Implant System Concept

- 04 Fixture Design
- 05 Abutment Connection
- 06 RBM_Fixture Surface Treatment
- 07 RBM+Brushite(CaP)_Fixture Surface Treatment

2. Package System

- 08 Package System / Label
- 09 Package Using Manual

3. SM / IFI Surgical kit

- 10 SM/IFI KIT
- 12 Site Preparation
- 14 Surgical Instruments

4. SM / SM Int. Master Surgical kit

- 19 SM/SM Int. Master KIT
- 20 Site Preparation

5. Prosthetic Surgical kit

- 22 Prosthetic Kit

6. Implant Closing & Healing

- 23 Implant Closing & Healing

7. SM-ExtraWide Implant

- 24 SM-ExtraWide
- 25 SM-Extra Wide Surgical Kit

DIO SM Implant System
Surgical Manual

Fixture Design

Double thread / Body-thread / Apex / Cutting Edge

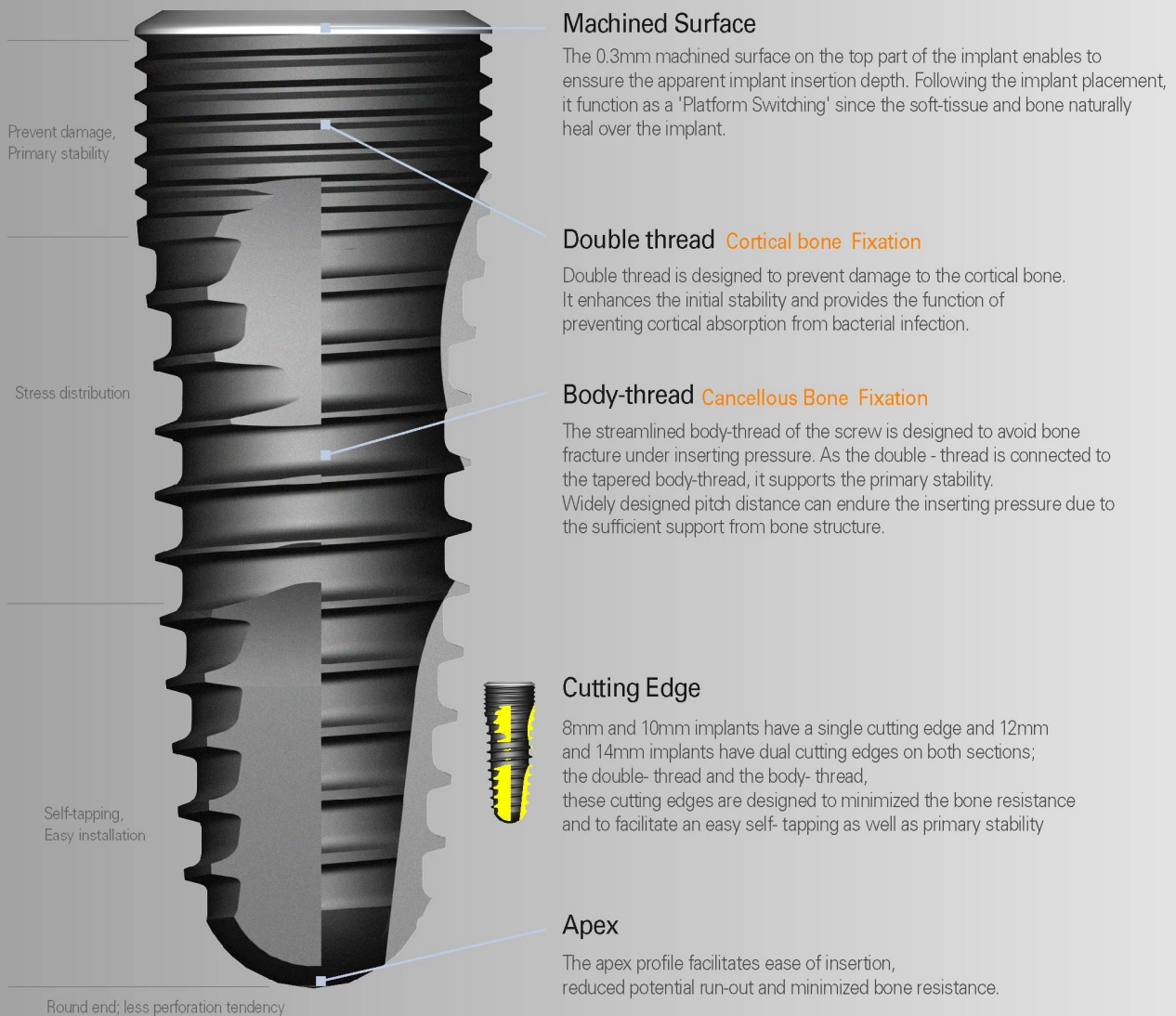

Fixture Design

Abutment Connection

Morse Tapered Surface / Torx Connection

Torx Connection

Torx type connection is applied to the implant and the counterparts.

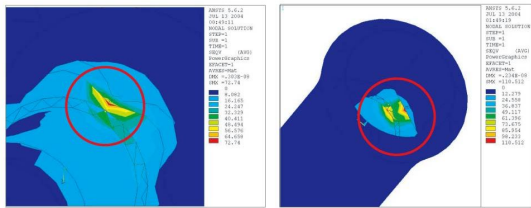

Torx type

Hex type

Torx type fixture is more advantageous, because the maximum concentrated stress caused by external force is reduced as much as 30% comparing to hex type fixture.

Morse Tapered

The internal Morse Tapered Surface for Narrow is 6° and Regular/Wide is 8°. The abutment is easier to be inserted with the internal Morse Tapered Surface. Because of the wider contact area with abutment, the potential possibility of screw loosening is reduced.

	Narrow	Regular	Wide
Morse Taper(θ)	6°	8°	
Morse Taper(\varnothing)	\varnothing 3.1	\varnothing 3.5	
Screw	M1.8	M2.0	

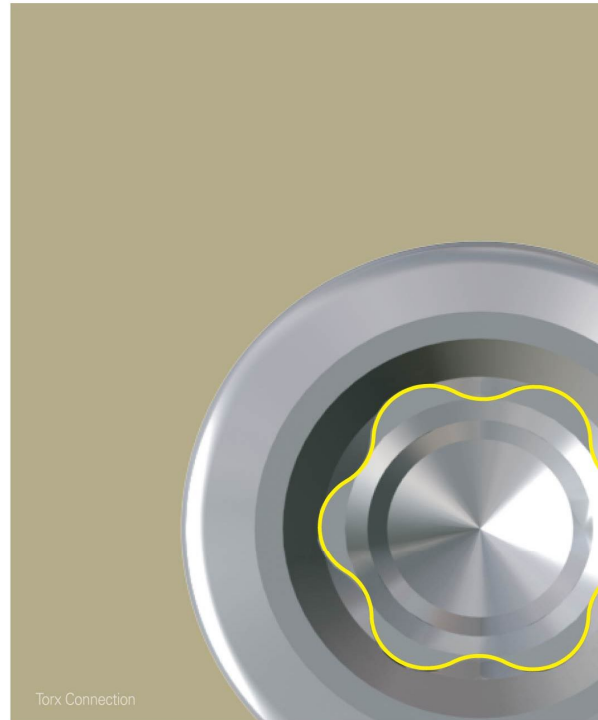

Torx Connection

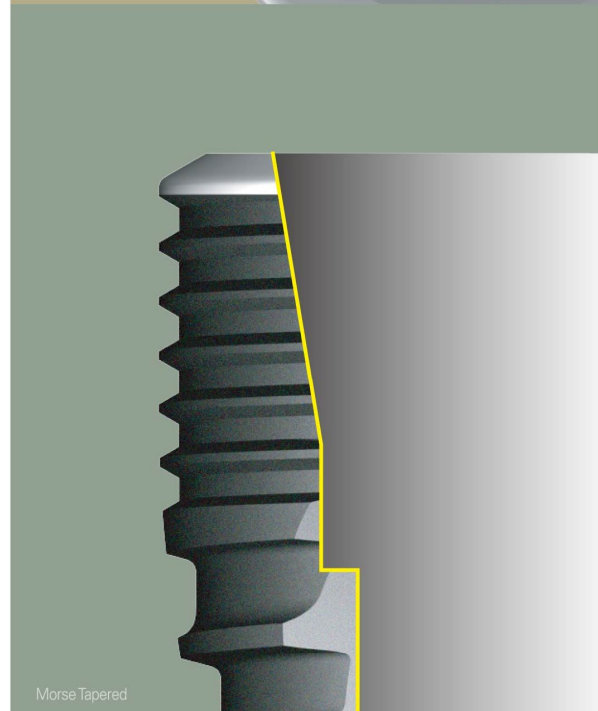

Morse Tapered

RBM

Fixture Surface Treatment

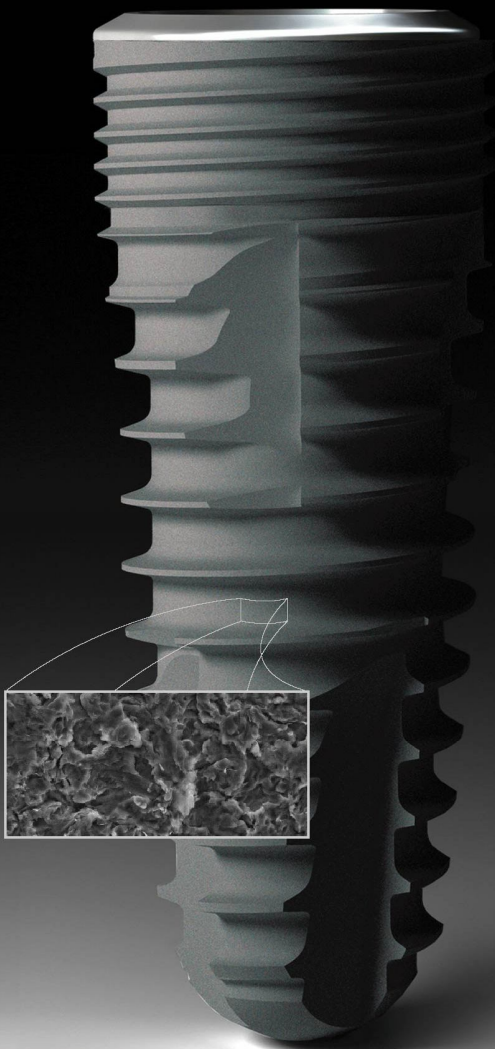

RBM (Resorbable Blast Media)

RBM surface treatment is a blasting process using absorbable particles that mainly consist of Hydroxyapatite (Beta-Tricalcium Phosphate, Alpha-Tcp, Ttcp, Calcium Pyrophosphate(CPP). It provides even roughness without leaving embedded debris and acid residue on the implant surface. Its successful clinical results were proven through a number of clinical cases. DIO Smile Implant System applies this RBM surface treatment to the implant surface that ensures even surface roughness of Ra 1.2 ~ 1.5 through an automated system.

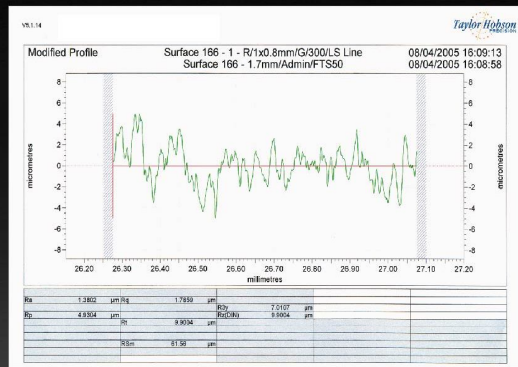

Roughness (Ra:1.2~1.5)

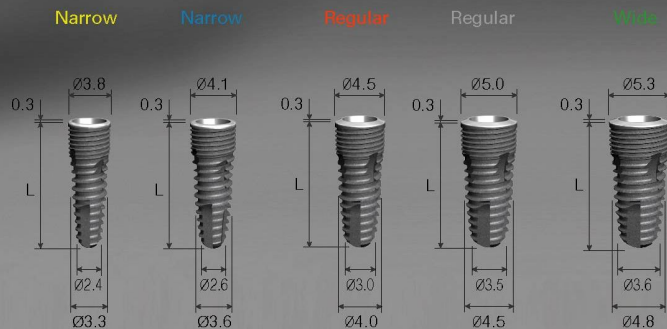

Length: 8, 10, 12, 14

RBM+Brushite(CaP)

Fixture Surface Treatment

BioTite-H

RBM+Brushite(CaP) (Dual Surface Treatment)

RBM surface treatment is selected for the Implant surface with roughness of Ra 1.2 ~1.5 and results in faster and superb osseointegration. Brushite, resorbable bioactive Calcium Phosphate, is coated on the RBM treated surface. Brushite coating electrochemically deposits bioactive brushite(CaP) as a thin layer ($15 \pm 5 \mu\text{m}$) into implant surface as a form of liquid layer including calcium and phosphate ion, resulting in shortened osseointegration period (6 to 12 weeks).

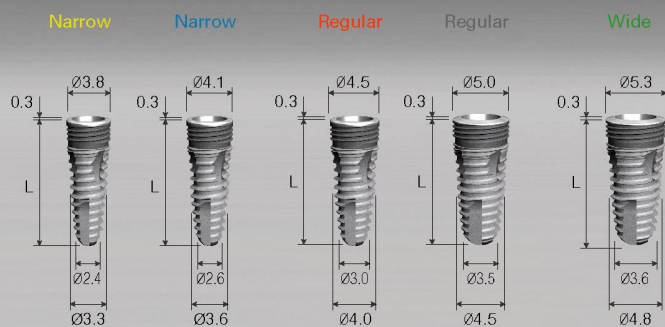
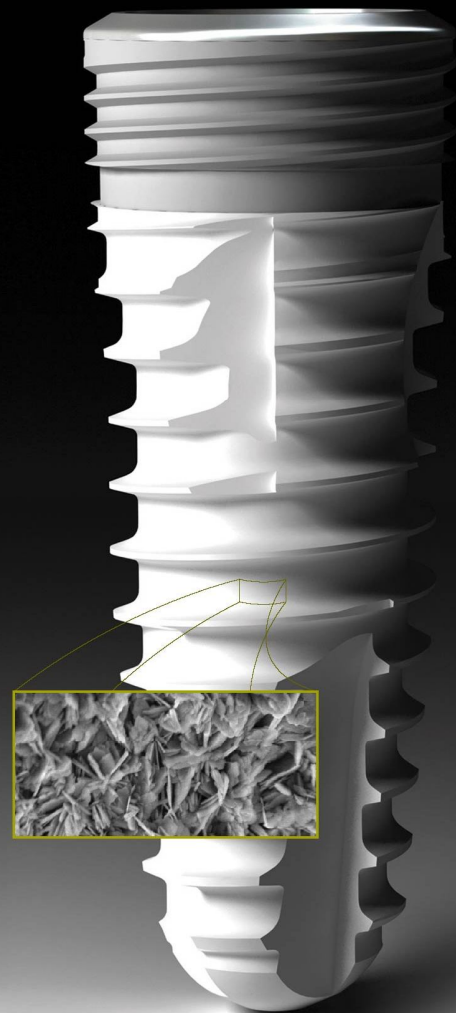
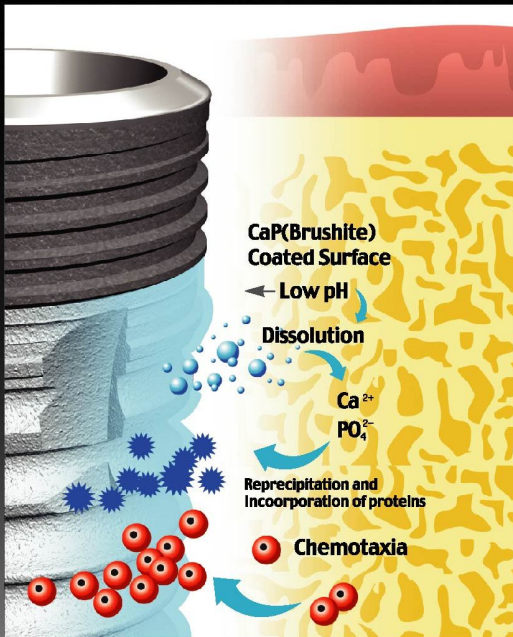

Length: 8, 10, 12, 14

Package System / Label

Fixture Package Label



- Fixture Size**
- (N) Narrow
 - (R) Regular
 - (W) Wide
 - (WN) Wide Neck
 - (TW) T Wide
 - (ALL) All Size
 - (N/R) Narrow/Regular
 - (R/W) Regular/Wide
 - (N/R/W) Narrow/Regular/Wide

Abutment Package Label



- Screw**
- Hex Screw Hex
 - Torx Screw Torx
 - SLOT Slot
- Abutment**
- Torx Torx
 - NON NonTorx
 - HEX Hex
 - OCTA Octa
 - Double HEX Double Hex
 - Single Single
 - Bridge Bridge

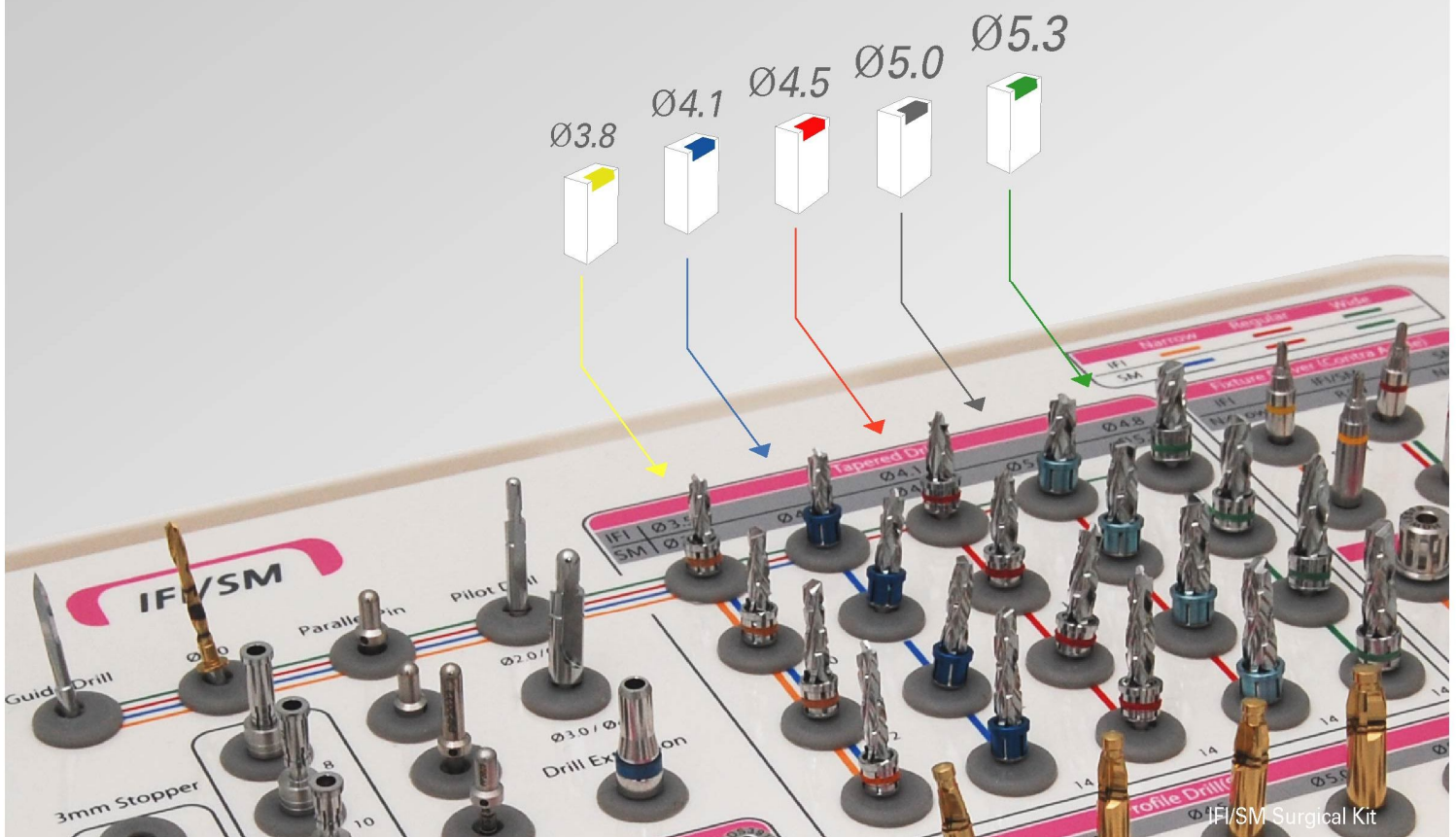

Package Using Manual

A. Opening package

1. Push the opening area in the upper area of package and open it
 2. Take the product out and check if the manual is included
 3. Open the paper seal of the fixture
- * put the chart sticker at the back of the paper seal into the form.

B. Taking out Fixture (type a)

1. Pull the transparent window containing fixture into the arrow direction indicated on the ampoule body side and open it about 30 degree.
2. Remove the ampoule cap and turn it inducing complete connection with fixture driver
3. Take fixture out after confirming complete connection

C. Taking out Fixture (type b)

1. Open the transparent window containing fixture almost horizontally against ampoule body
2. Shake the window left to right and completely detach ampoule body.
3. It is easy to use when detached

Taking out Cover Screw

1. Open the screw cap of the ampoule body
 2. Connect the hex driver to the cover screw
 3. Turn the hex driver counterclockwise (screw loosening direction) and take it out
- * After turning, incline it to the side and pick it up

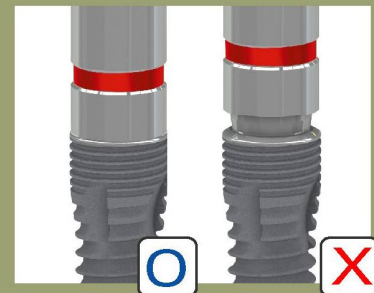

Proper fixture connection

When incompletely connected, fixture inside torx can be damaged and caution is needed



IFI/SM KIT

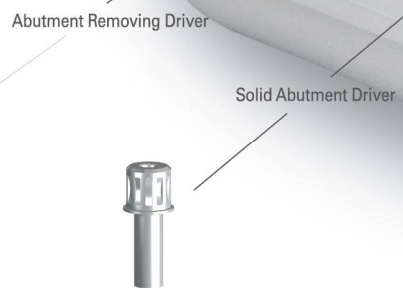
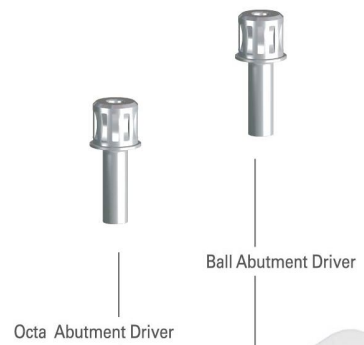
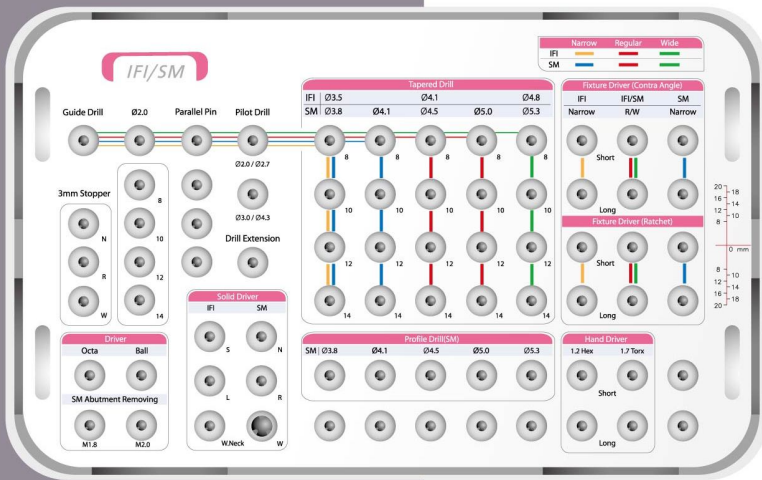

*Bottom Tray



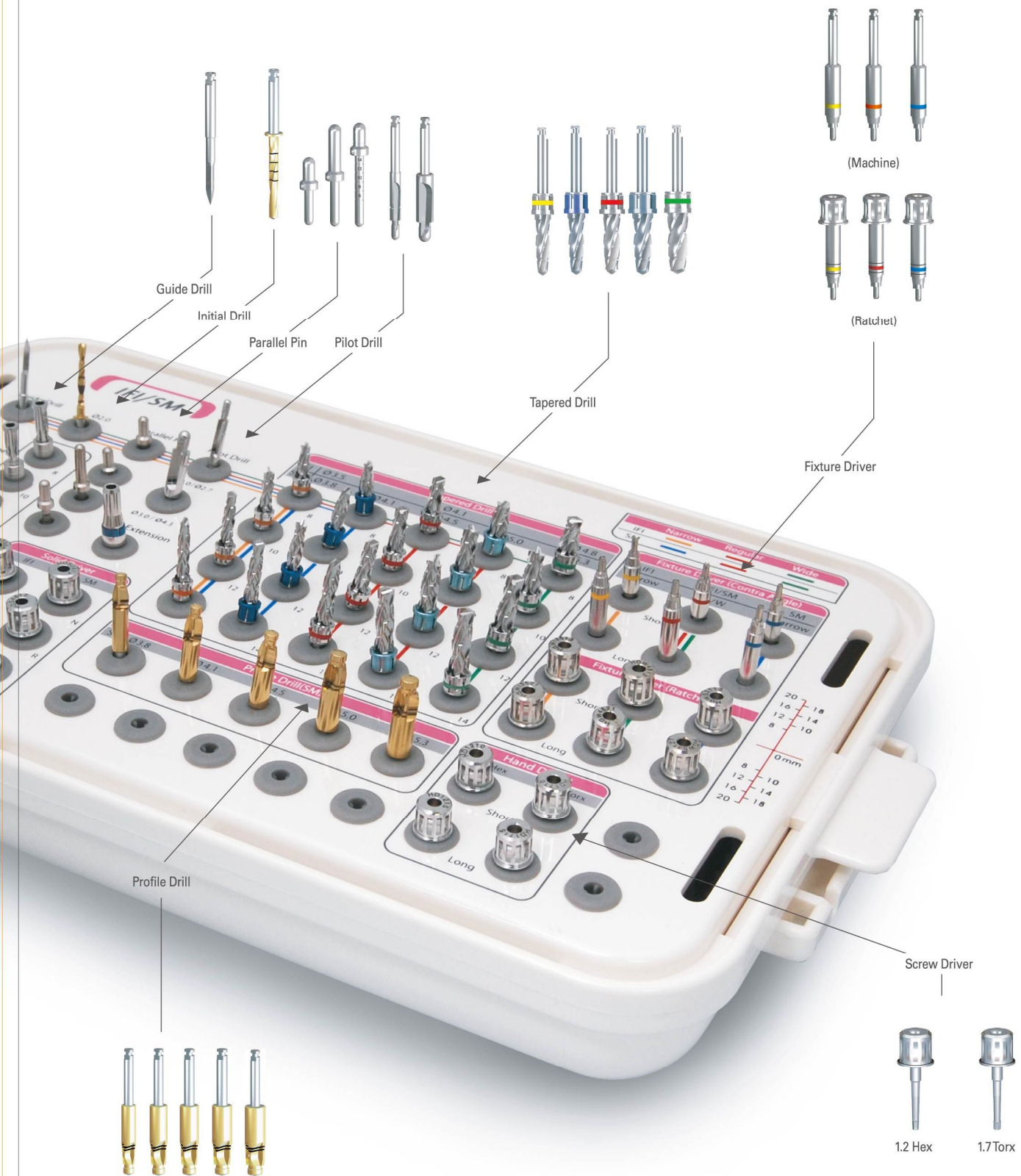

Site Preparation

*Drilling The variations in bone density mandate different clinical and biomechanical considerations in treatment planning and implant placement for the various bone qualities

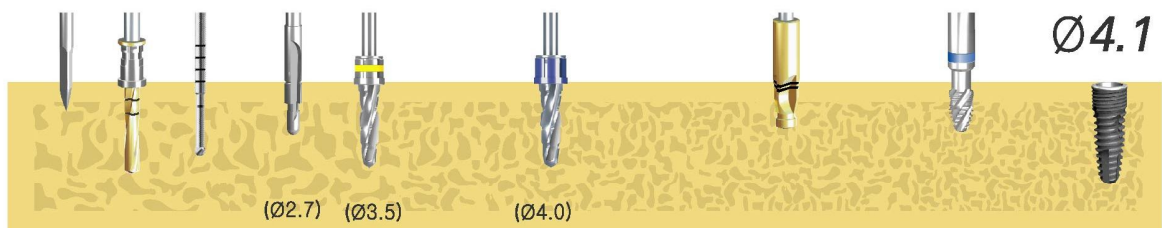
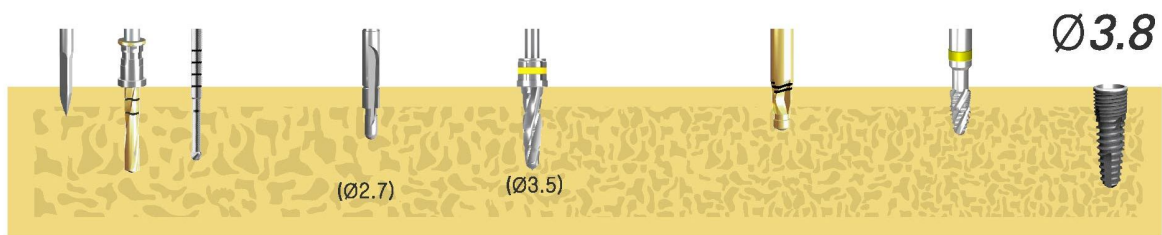
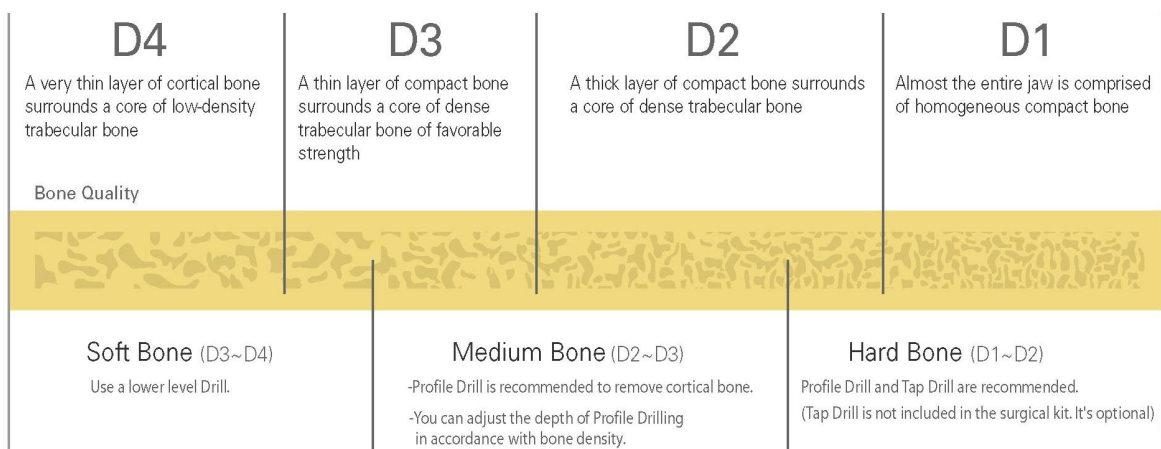

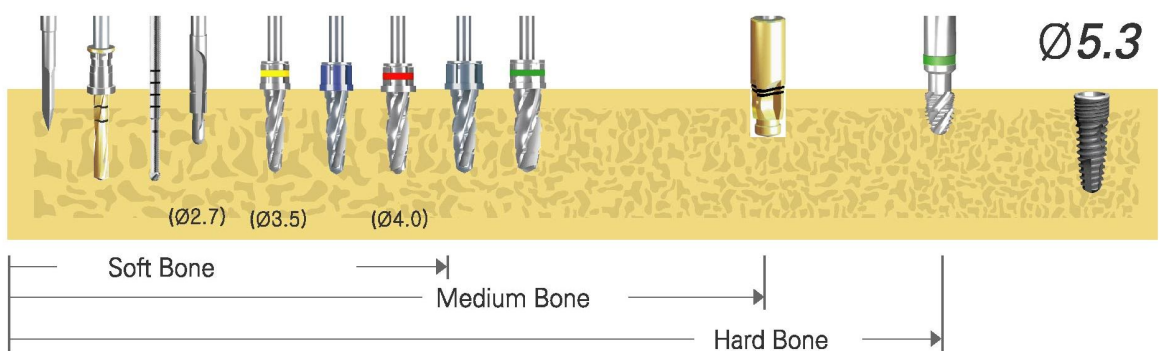
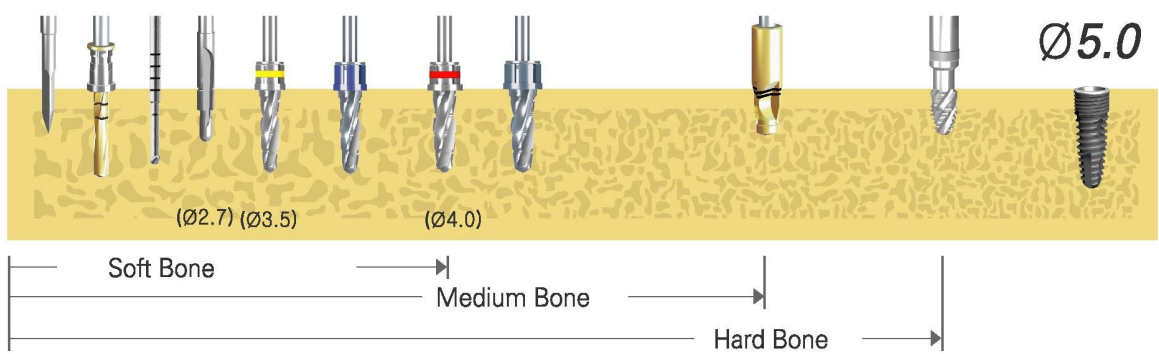
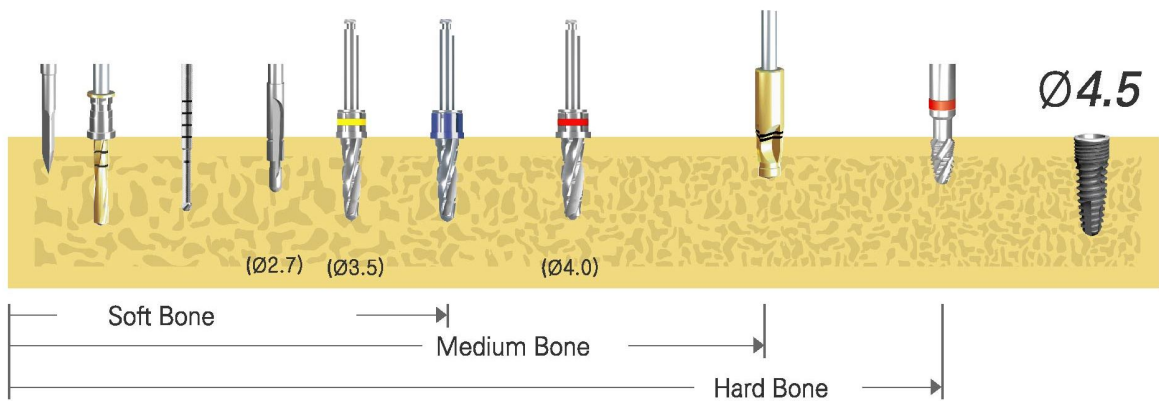
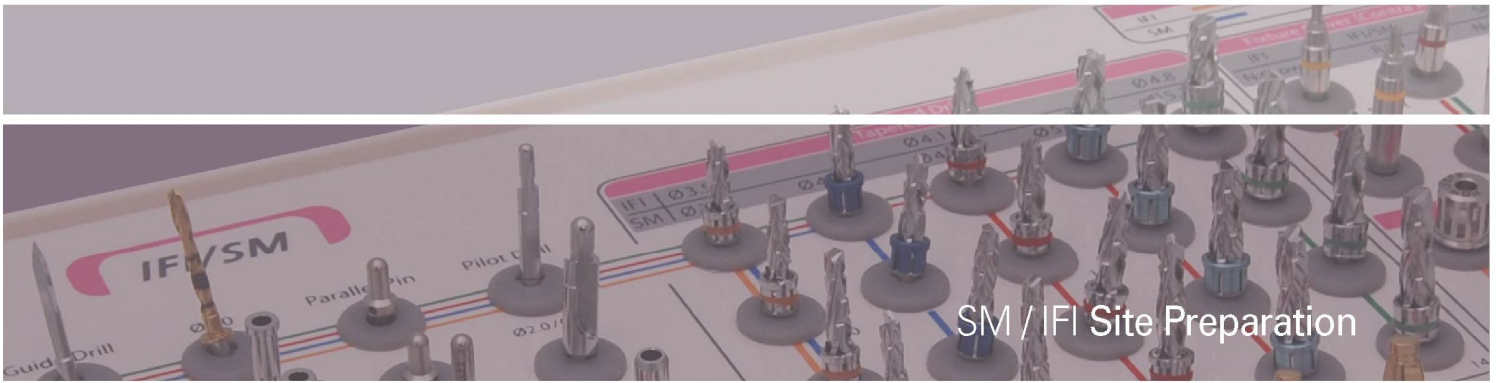

Surgical Instruments



Guide drill

To drill through the cortical bone and fix the position for implantation.
Drilling depth:
Can be visually checked.
Drill to a depth where makes easy driver of initial drill.



Initial drill

To be used for development of osteotomy site of cortical bone.
Drilling depth:
According to the length of the implant, insert an appropriate stopper length to ensure correct depth of drilling into cortical bone.
***Warning: Do not insert a stopper upside down.**



Positioning Guide

Marks space between fixtures
Used after initial drilling



Pilot drill

To adjust the slope or location of the osteotomy site formed with a initial drill.
To guide the drilling location before Widening the osteotomy site.



Depth gauge

Measuring a depth by inserting the bent measuring section of the depth gauge into the osteotomy site formed at cortical bone.
For Identification, it has markings at 8, 10, 12, 14, 16 and 18mm from the bottom, which correspond to the depth of the implant.



Parallel Pin

Provides location and direction of site preparation
Drill site depth survey

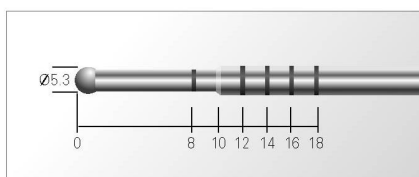

Lindemann Drill

Provides drill direction adjustment
Useful in site preparation and ridge reduction in extractions

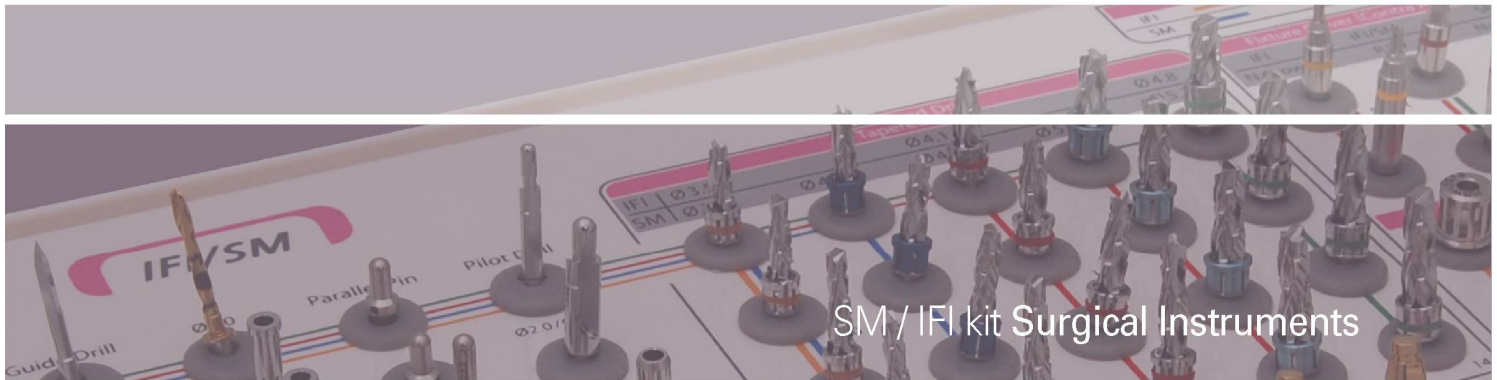

Tapered drill

To be used for intermediate or Final Drilling(800 - 1,500rpm).
It has the best matching diameter and length to the implant.
With its own rotation type stopper, it enables to simply drill an accurate depth.

Rotation Type Stopper

- It provides more accurate and easier drilling.
- The DIO Stopper can be attached and detached from the drill and is easily to be cleaned after use.
- The bone is protected from damage caused by fixed type stopper.
- The length of standard stopper is 4mm in the kit. And if you want to place implant 1mm deeper than implant length, you can use 3mm stopper. (3mm stopper is not included in the surgical kit. It's optional)

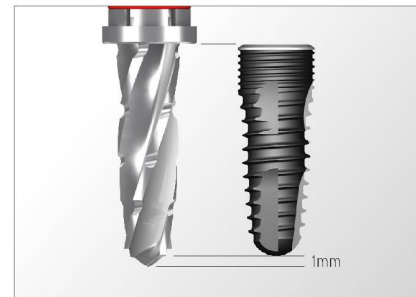

*The length of Drill Tip(1mm) is not included in the length of Drill. So please be careful during drilling.



Profile drill

Used to shape top of fixture (Straight & Taper shape)

Insertion depth: Drilling depth is determined by bone tissue.
Drills up to B depth in case of D1/D2 bone.
Tap drill is recommended in cases where the D1 bone tissue is resistant.
Drills up to A depth in case of D2/D3 bone.
Profile drill is not recommended in cases where the D4 bone tissue is weak.

This drill is designed to prevent excess torque
Implant depth is adjustable

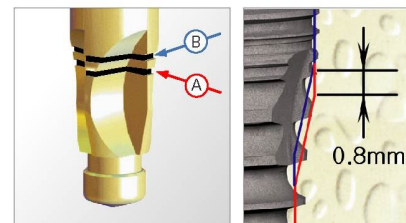

Tap drill

The osteotomy should be tapped in dense bone following the final profile drill used in the preparation of the osteotomy
D1 bone typically requires that the full length of the osteotomy be prepared with the tap.
D2 bone, as well as bone with a thick inferior cortical plate, might also require full-length preparation. if only the superior cortical plate is dense and it is not planned for the implant to engage the inferior border, the tap drill should be used in the area only.
The use of a tap drill is suggested in D3 bone when one (or two) side of the osteotomy are in contact with a lateral cortical plate quality.

Drill Extension

Provides extra length for drills used with handpieces
Connects to the flat surface of the drill shank



Surgical Instruments

Torque Wrench Guide

The DIO Torque Wrench have designed to use the Bar Spring to apply the torque value.
Also, the Bar Spring consists of SMA(Shape Memory Alloy) that provides longer usage period & adjustable torque value while pulling it.

- Before sterilizing the Torque Wrench, Remove the Wrench Screw with 1.2 Hex Driver.
Caution) Do not force to separate completely. It's not designed to be separate completely due to avoiding screw loss.
- Dry sufficiently after sterilize

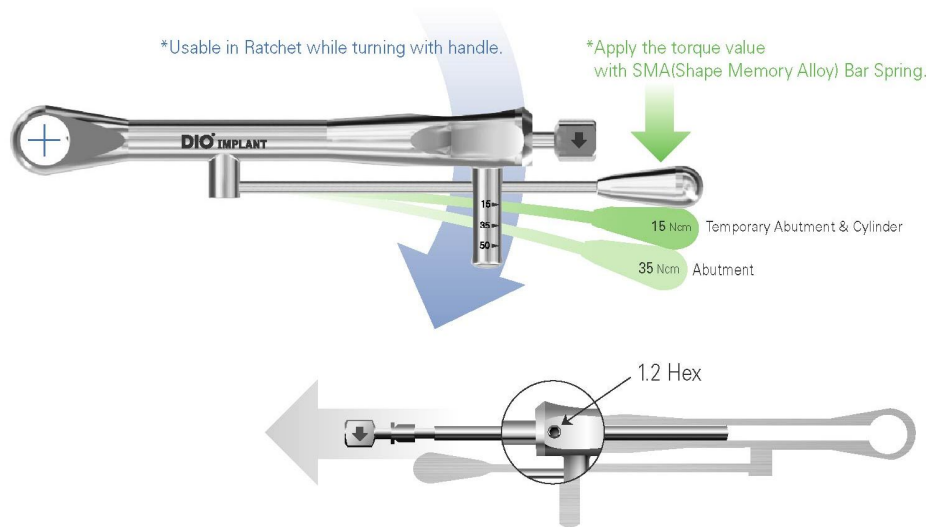

Open Wrench



- For stability on tightening or loosening of the ratchet driver.
- Use by fixing the pin of the open wrench to the hole on the upper part of the driver.
- *The holding key section is used external fixture driver.

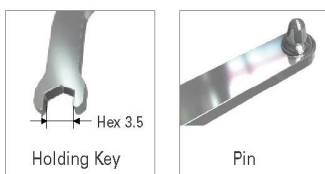

Use of open wrench



Before use

After use

Use of holding key



Application to external fixture mount driver.

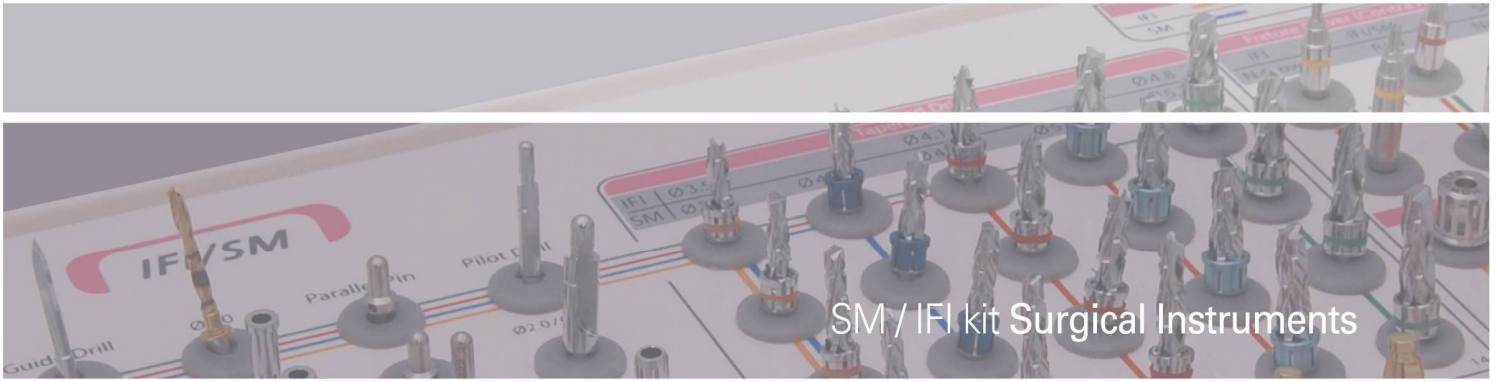

SM / IFI kit Surgical Instruments



Machine



Ratchet

Fixture Driver

Proper fixture connection

When incompletely connected, fixture inside torx can be damaged and caution is needed

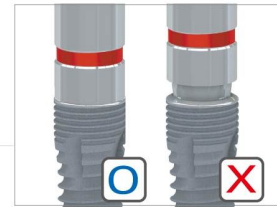

Machine



Ratchet

Screw Driver

Used for connecting torx shape component into fixture
Torx type or Hex type used according to connection type

- Headless, Closing Screw, Healing Abutment, Pick-up /Transfer Impression Coping : 1.2 Hex Driver
- Abutment : 1.7 Torx Driver



Ball Abutment Driver

Used for connecting the Ball Abutment on the Fixture.

Torx Abutment Screw

- Normal hexa type coping screws can be distorted easily by a force of 35Ncm.
- Torx type connection is applied to implant and counter parts.
- The DIO screw is not distorted by repeated tightening and loosening.



Solid Abutment Driver

Torque confirmed only after driver is firmly engaged with the solid abutment driver



Caution)

Please use 1.7 torx driver only.
(Torx screw can be damaged if used 1.2 hex driver.)



Fixture Mount Driver

Used for implanting the fixture with Mount.

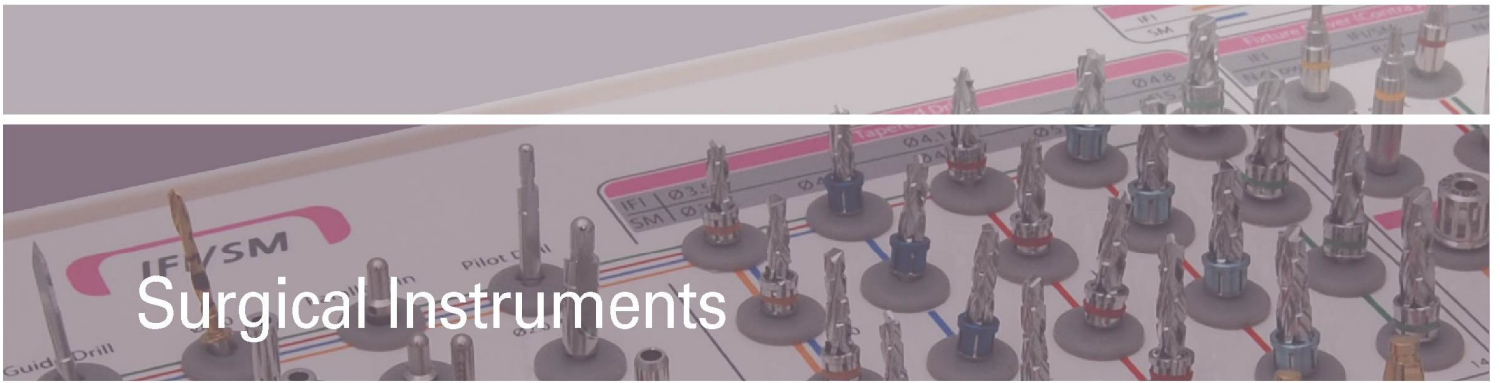

Removing Driver

- To detach abutment from implant or implant analogue.
- *Application: Cemented Abutment, Angled Abutment, Temporary Abutment, UCLA Gold Abutment.
- After the abutment screw has been completely removed, the removing driver is assembled on the abutment, and then tighten in the direction of screw to remove the abutment.
- Use hand or ratchet wrench for removing driver.
- The different types of removing drivers are applied to Narrow and Regular/Wide implant.

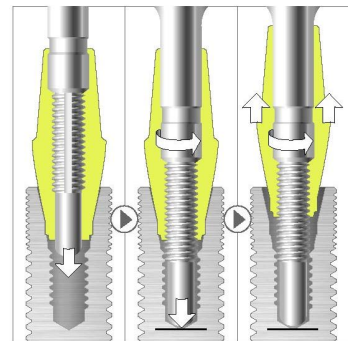

Tissue Punch

Used for making hole on soft tissue



Trephine Drill

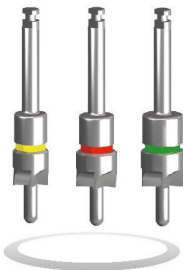

Bone Planer

- Where bone is uneven and irregular, the bone planer flattens bone in order to maximize the function of the rotation type stopper.
- To be used after initial drilling(Ø2.0)
- Insert its guide part into a drilled osteotomy site and remove the undesired bone.
- Handpiece Speed: 400–600rpm

SM/SM Int. Master KIT

- Lindermann Drill addition
- SM only drill set integrating the tapered drill and profile drill
- Rotation stopper
- Clear color mark
- *SM External has a separate fixture driver

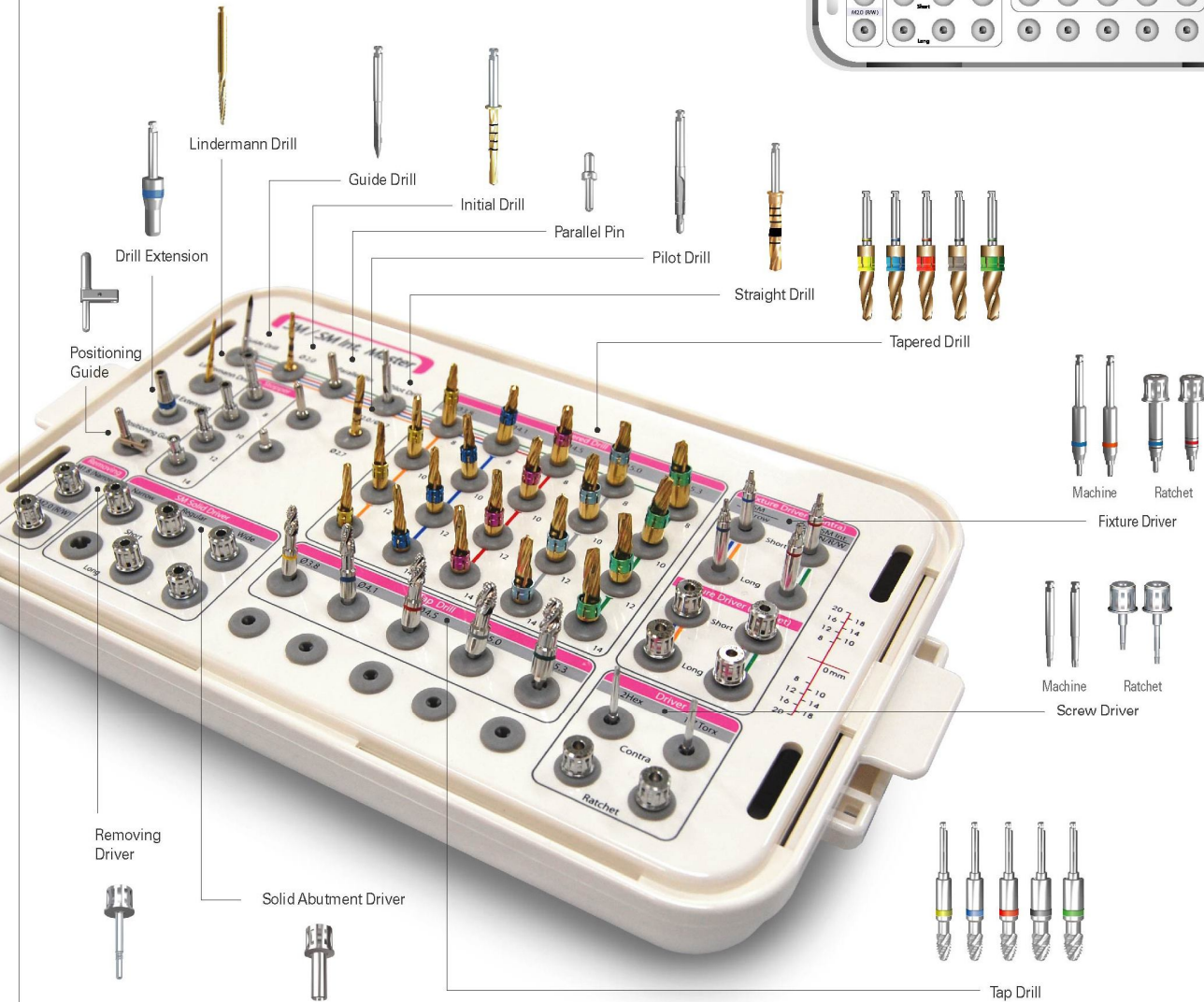
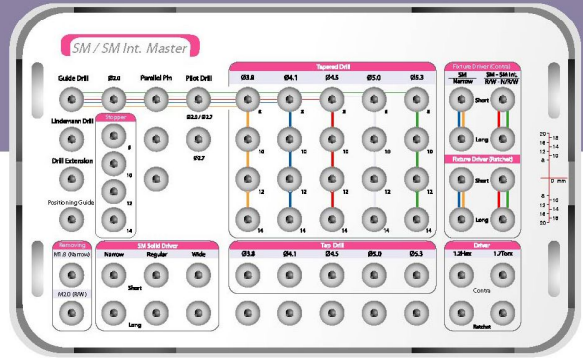

*Bottom Tray



Open Wrench



Depth Gauge



Torque Wrench

Site Preparation

*Drilling The variations in bone sensity mandate different clinical and biomechanical considerations in treatment planning and implant placement for the various bone qualities

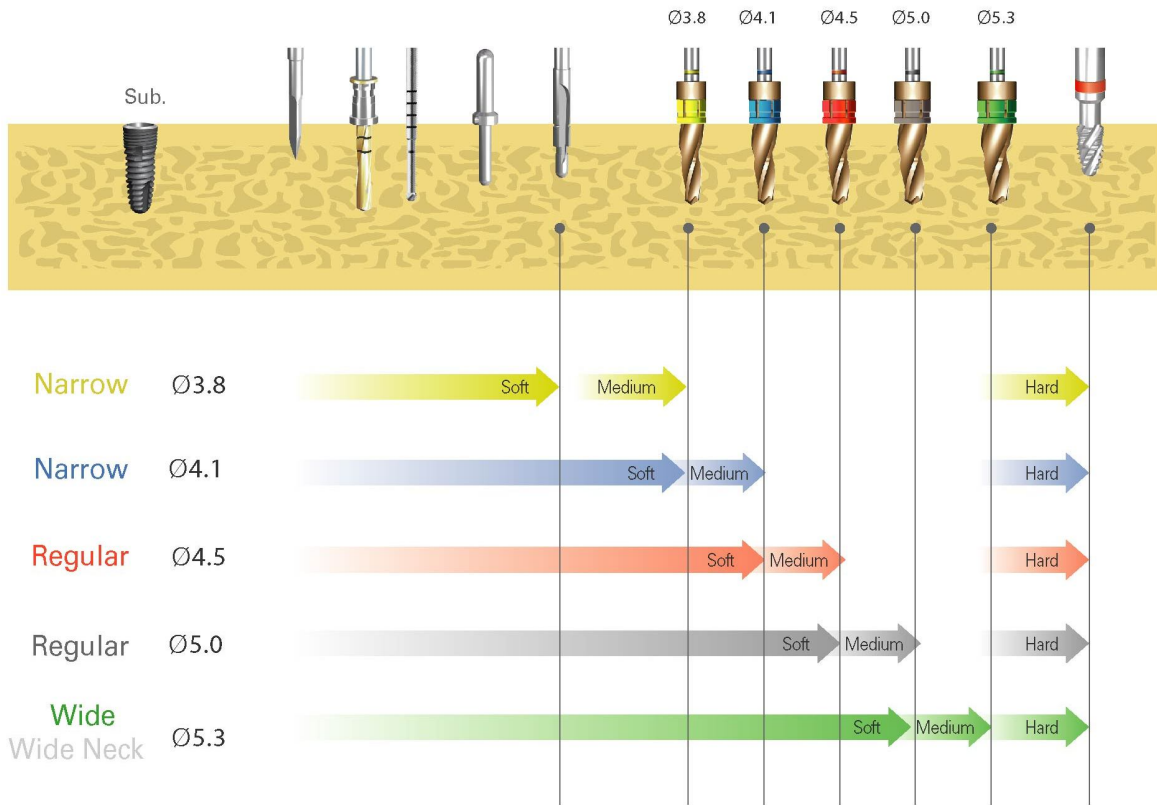
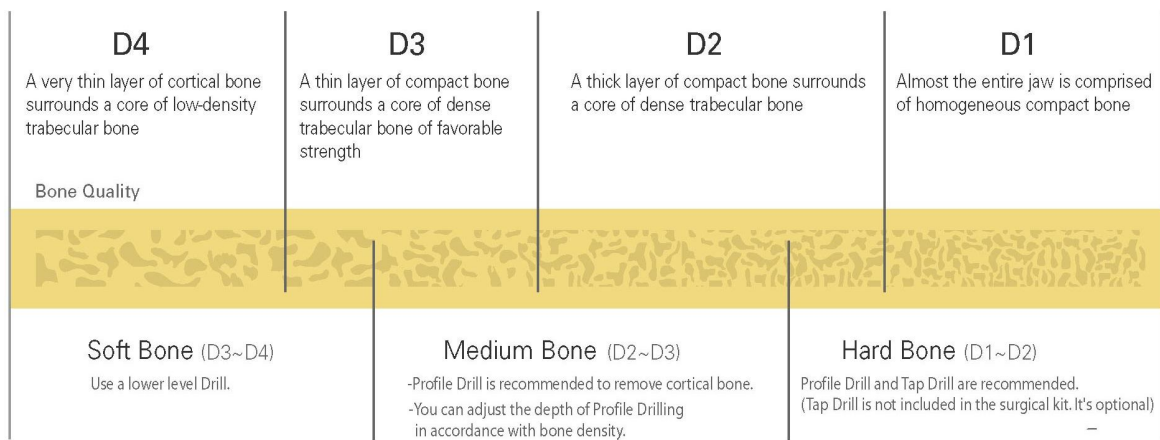

*To placing implant on the Medium Bone with the diameter of 5.0/5.3, It's decidable by implantologist to use Tap Drill.

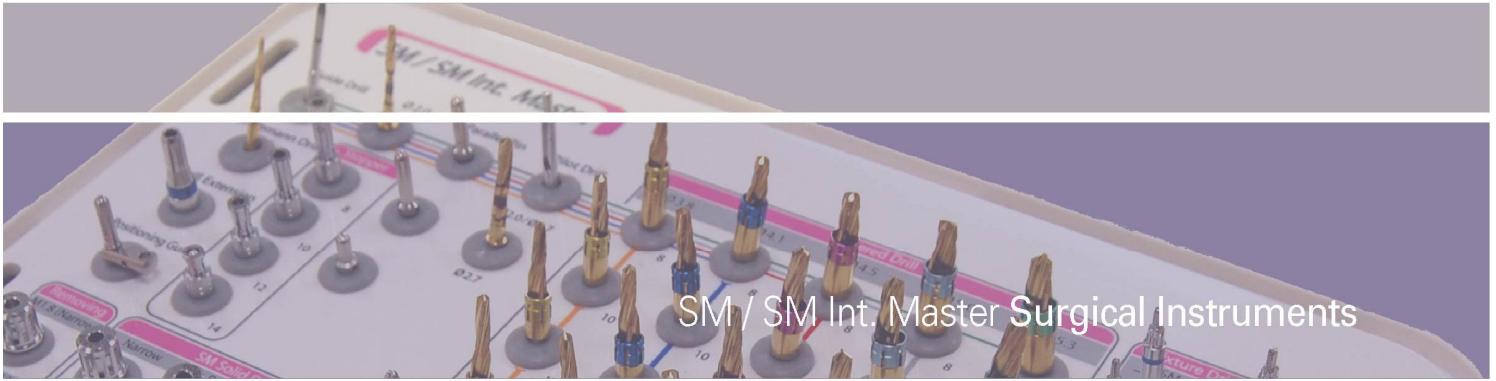

SM Tapered Drill

SM-only drill integrated tapered drill with profile drill

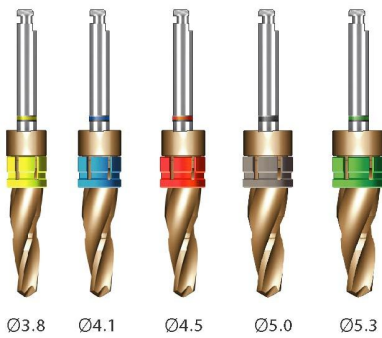

Rotating stopper

Guarantee correct drilling depth conveniently.
Can be easily attached and detached from a drill body
and easy to clean it
Minimize bone loss

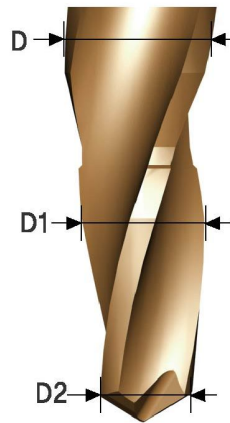

Diameter		Ø3.8	Ø4.1	Ø4.5	Ø5.0	Ø5.3	
Length	8	D	Ø3.55	Ø3.85	Ø4.25	Ø4.75	Ø5.05
		D1	Ø2.7	Ø3.0	Ø3.4	Ø4.0	Ø4.3
		D2	Ø2.06	Ø2.35	Ø2.75	Ø2.36	Ø3.6
10	D	Ø3.55	Ø3.85	Ø4.25	Ø4.75	Ø5.05	
	D1	Ø2.8	Ø3.1	Ø3.5	Ø4.0	Ø4.3	
	D2	Ø2.24	Ø2.59	Ø2.99	Ø3.49	Ø3.57	
12	D	Ø3.55	Ø3.85	Ø4.25	Ø4.75	Ø5.1	
	D1	Ø2.8	Ø3.1	Ø3.5	Ø4.0	Ø4.5	
	D2	Ø2.03	Ø2.23	Ø2.63	Ø3.13	Ø3.63	
14	D	Ø3.55	Ø3.85	Ø4.25	Ø4.75	Ø5.1	
	D1	Ø2.8	Ø3.1	Ø3.6	Ø4.1	Ø4.5	
	D2	Ø2.03	Ø2.23	Ø2.73	Ø3.23	Ø3.63	

D part has bigger diameter to function as profile drill
Need caution not to have heavy torque while drilling into hard bone

Prosthetic Kit

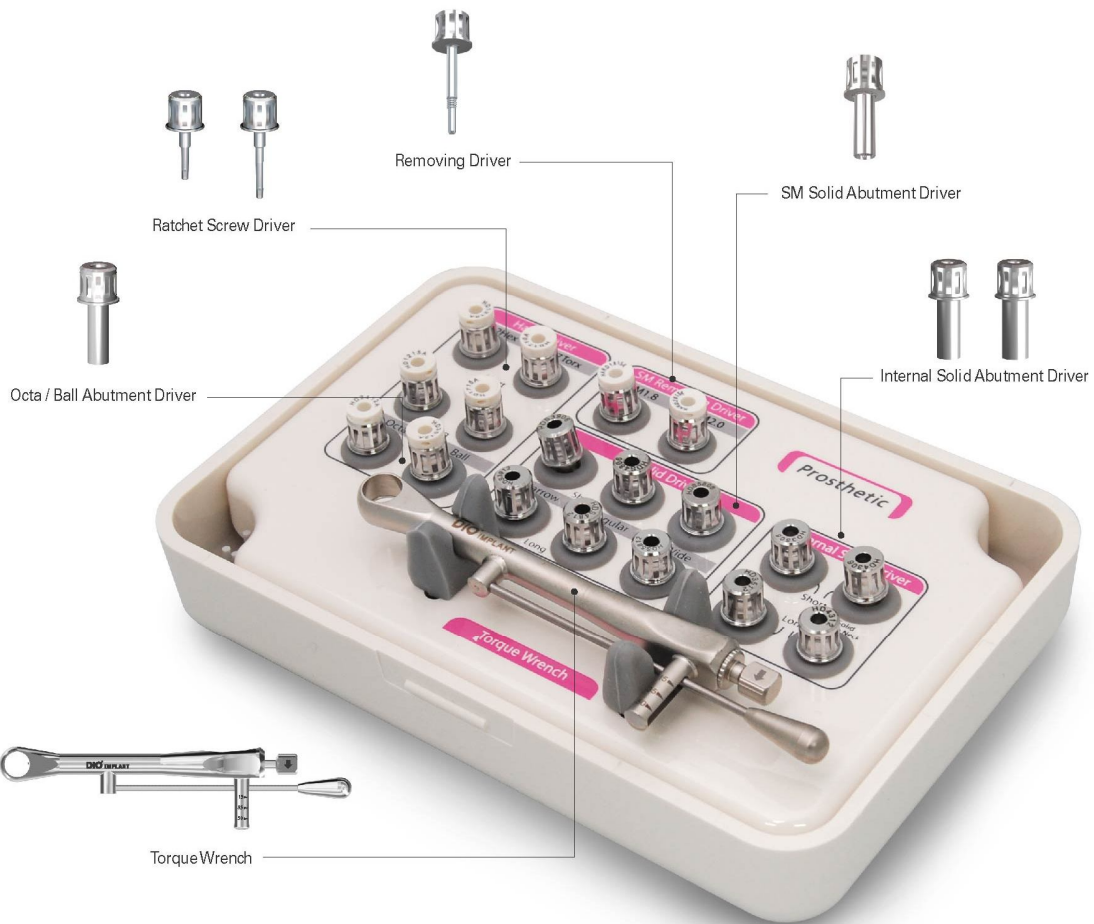
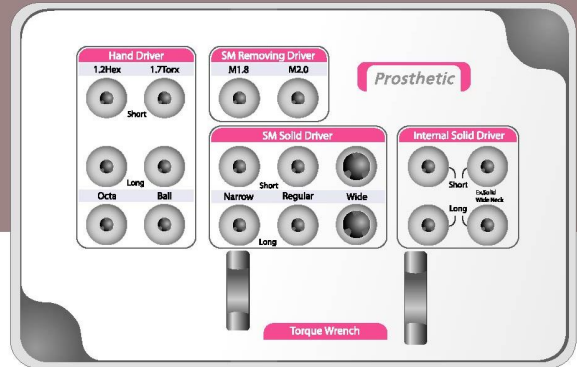

*Bottom Tray



Implant Closing & Healing



Headless

In case of narrow interdental, difficult to use toll
in case of less soft tissue for suture, protect fixture connection area



Closing Screw

Used for One stage surgery can be used as alternative
for healing abutment



Healing Abutment

Soft tissue open until selecting abutment form proper emergence profile
helping complete cure of soft tissue after surgery

Connect using 1.2 hex driver by hand (5~8Ncm)

Hex can be distorted by heavy torque when removing screw in case of cold-welding occurred between screw and fixture.
In order to prevent this problem, connect screw after getting rid of blood or impurities inside fixture.
spread of antibiotics when closing screw, it will be easily disconnected.



SM-ExtraWide

RBM / Biotite-H Implant

Tapered Design

Early loading possible in the initial seating
 Minimized bone heating
 Screw pitch: 0.8mm, Thread height: 0.5mm

Internal Torx Connection

Superior to Hex internal connection
 More fixture and driver contact
 No distortion with high torque

No-mount System

Does not require disassembling of mounts during surgical operations
 Increases convenience and decreases time of surgical operation

Convenient Compatibility System

Compatible with the SM Submerge Implant

Platform Switching

"Platform Switching" technique is applied to the design of the implants and abutments to reduce cretal bone loss

RBM Implant

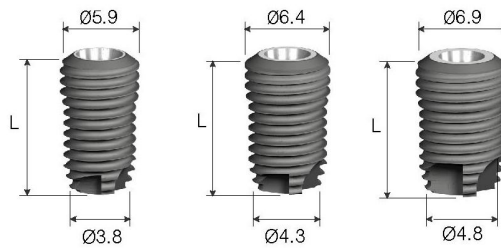

Internal Torx Connection



Length

6 mm
 8 mm
 10 mm

Biotite-H Implant

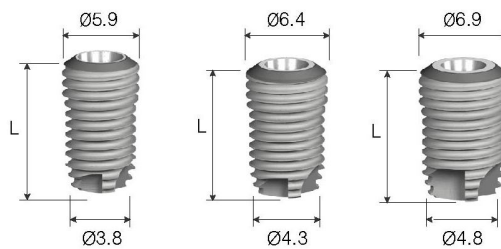

Internal Torx Connection



Length

8 mm
 10 mm

Surgical Kit

SM-Extra Wide

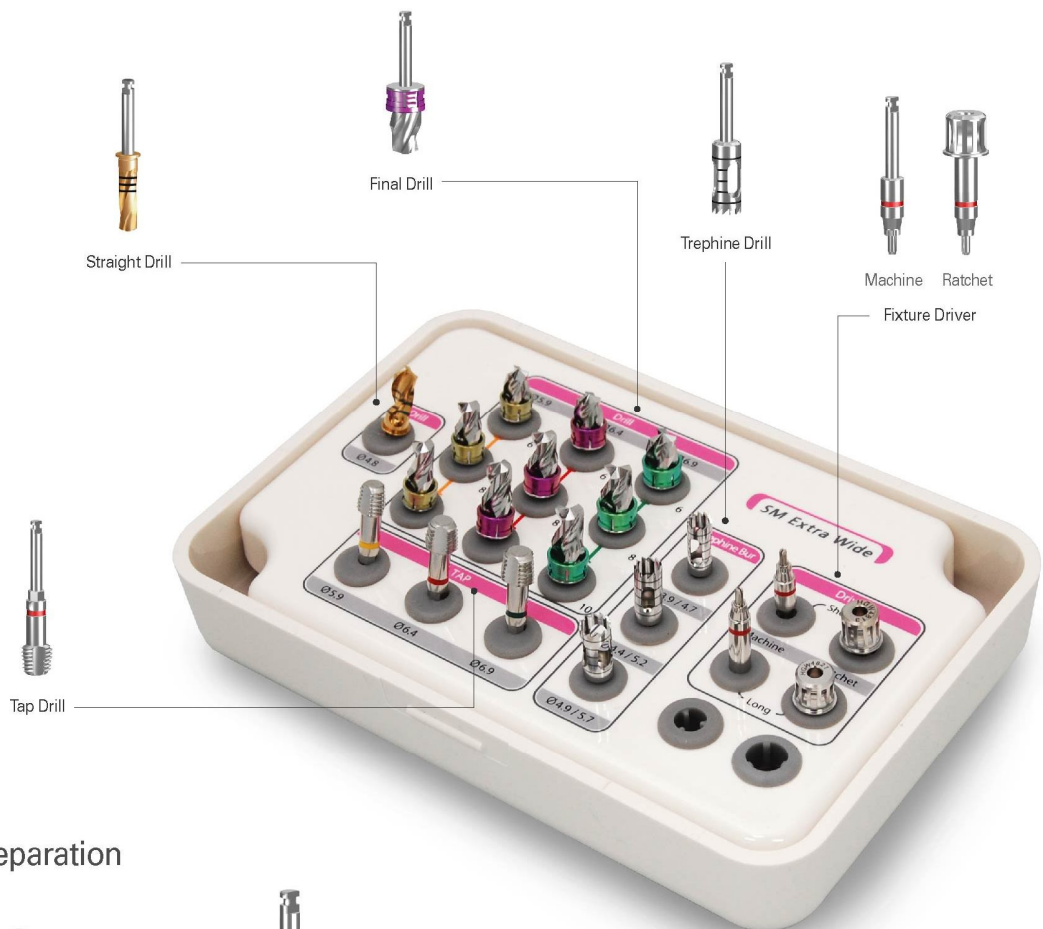
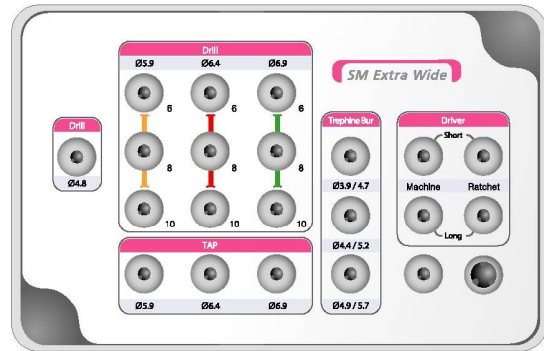

Site Preparation

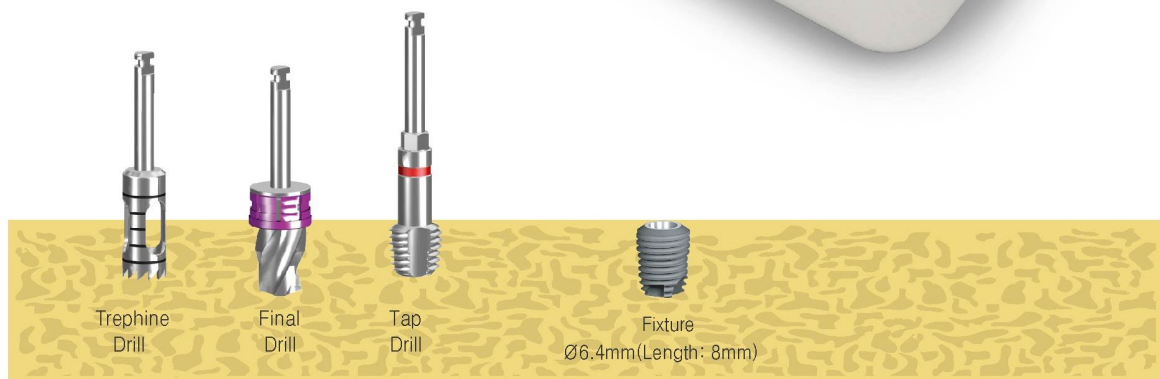



DIO IMPLANT

1464 U - dong Haeundae - gu , Busan City , Korea

Tel. +82 - 51 - 745 - 7777

Fax. +82 - 51 - 745 - 7778